

12 V_{DC} FAA L-810 and ICAO Low-intensity, Type B Obstacle Light

Key features

- Extremely reliable - long lifetime
- Very low power consumption
- 12 V_{DC} nominal supply voltage
- Intensity 37 cd typical
- Stabilised light output
- Lightweight and small – low wind load factor
- Easy to install
- Absolutely no RF-radiations

Benefits

- Long maintenance intervals
- Low energy cost
- Supply power voltage variations do not affect to light output
- Very low total lifetime costs
- Low wind load
- Comes with five (5) years warranty

Specifications met

- ICAO International Standards and Recommended Practices:
Aerodromes - Annex 14 Volume 1, 5th Edition, July 2009,
Chapter 6: Low-intensity, Type B Fixed Obstacle Light
- FAA Advisory Circular 150/5345-43F 09/12/06 L-810 Light Unit

Optical characteristics

- Intensity better than 32 cd (37 cd typical)
- Colour aviation red
- Horizontal radiation pattern 360°
- Vertical radiation pattern 50°
- LED supply current stabilised by constant current generator
- Light output degradation less than 25% after 100.000 h of operation

Electrical characteristics

- LEDs in several separate groups
- Nominal operating voltage 12 V_{DC}
- Power consumption less than 8 W (< 0,6 A Constant Current)
- Operating voltage range 12 ... 19 V_{DC}
- Two-stage over-voltage protection
- Terminal box for 2,5mm² wires
- Easy to chain

Mechanical characteristics

- Yellow painted aluminium body
- Colourless (clear) glass cover
- Weather protection to IP 65
- Operating temperature range -55°C ... +55°C
- Height 235 mm, diameter 120 mm, weight 0,9 kg
- Wind load with CS-60 mounting kit @ 200 km/h less than 40 N

Options

- MS-60 Mounting kit
- MS-100 Mounting kit
- PCFL-DC1-B Photocell
- CSW Photocell/Change Switch Unit

Ordering Code: **Obelux 32-12-F**
Made in Finland



Obelux 32-12-F

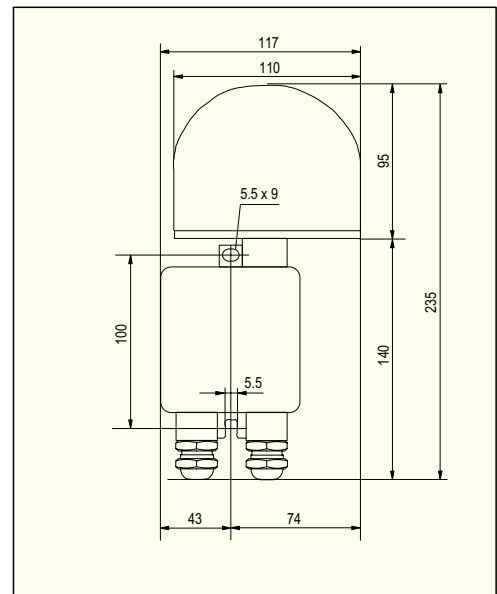

Obelux 32-12-F dimensions

	OPERATING VOLTAGE 12 VDC
	CAUTION ! LED RADIATION DO NOT STARE INTO LED BEAM OR VIEW DIRECTLY WITH OPTICAL INSTRUMENTS. CLASS 2A LED PRODUCT

Technical information in this document is subject to change without notice. Copyright © Obelux Oy 2010

12 V_{DC} FAA L-810 and ICAO Low-intensity, Type B Obstacle Light

Obelux 32-12-F is an obstacle light utilizing LED technology. The cabling and installation principles are similar to those of conventional obstacle lights, the only exception being the correct polarity required by DC feed.

The recommended polarity is:

Blue -
Black +

All connection alternatives can be protected with a 6 A or 10 A fuse or with a circuit breaker (C curve).

Technical specifications

- Operating voltage: 12 VDC
- Power consumption: < 8 W
- Current consumption: < 0,6 A
- Two-stage overvoltage protection
- Weather protection: IP65
- Operating temperature range: -55...+55 °C
- Height: 235 mm
- Diameter: 120 mm
- Glass cover thickness: 5 mm
- Terminal box: yellow powder painted die cast Aluminium
- Weight: 0.9 kg

Installation specifications

- Cable gland: PG 16
- Cable diameter: 8...14 mm
- Wire diameter: max. 6 mm²
- Recommended cable: 4x1.5+1.5 or 2x1.5+1.5 mm²
- Fixing hole distance: 100 mm
- Fixing screw diameter: max. 5 mm
- Fixing base thickness: 5 mm

Mounting sets

- MS-60: Mounting onto Ø 30...60 mm pipes
- MS-100: Mounting onto Ø 60...100 mm pipes
- U-bolts and hex nuts M8: acid-proof steel
- Mounting plate: black anodized aluminium

Options

- MS-60 Mounting kit
- MS-100 Mounting kit
- PCFL-DC1-B Photocell
- CSW Photocell/Change Switch Unit

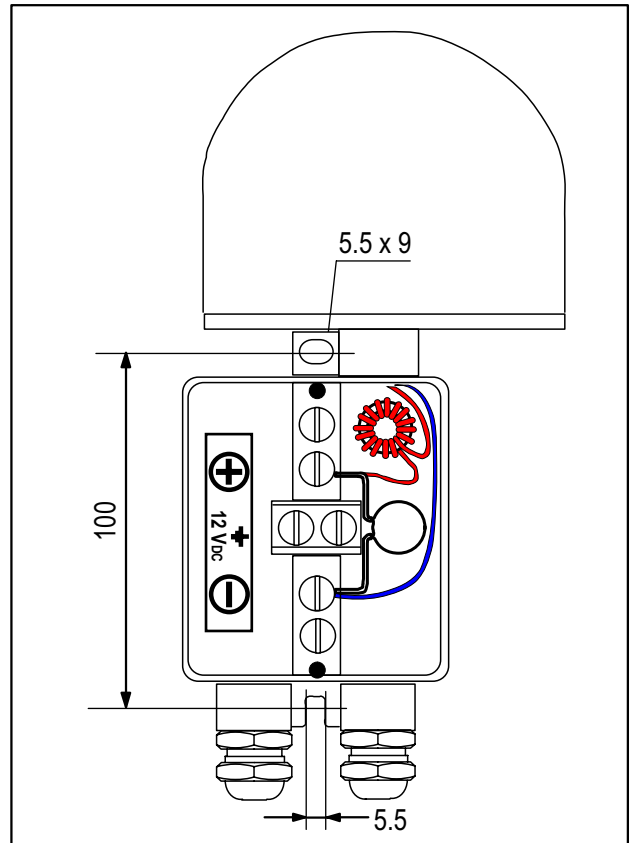

Obelux 32-12-F terminal box

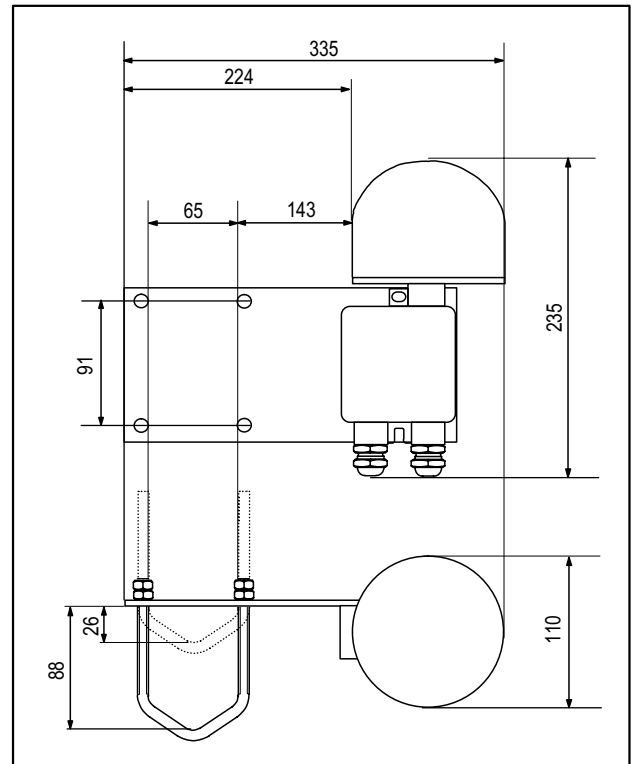

Obelux MS-60 mounting set

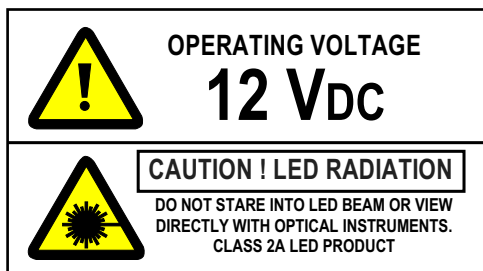

Technical information in this document is subject to change without notice. Copyright © Obelux Oy 2010